

INSTRUCTION MANUAL

AL-320G Bench Lathe (240V) 250 x 500mm

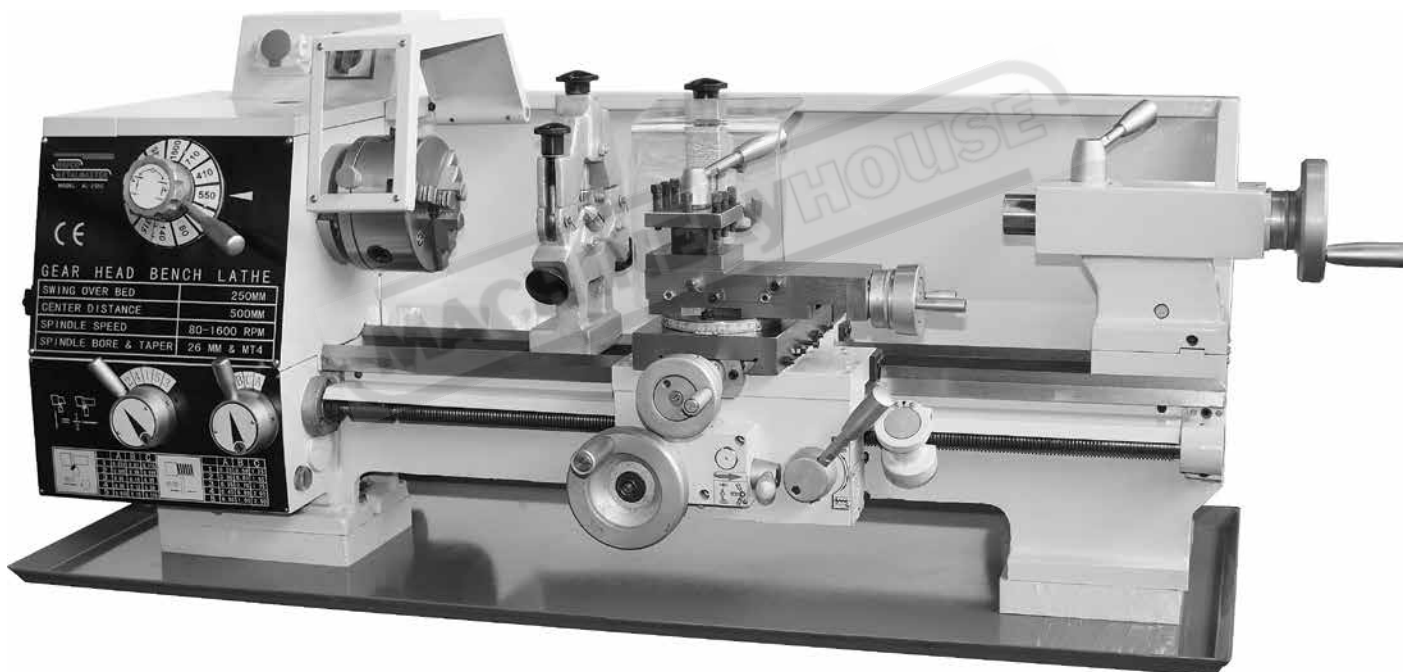

GENERAL SAFETY INSTRUCTIONS

EXTREME CAUTION SHOULD BE USED IN OPERATION ALL POWER TOOLS. KNOW YOUR POWER TOOL, BE FAMILIAR WITH ITS OPERATION. READ THE OWNER'S MANUAL AND PRACTICE SAFE USAGE PROCEDURES AT ALL TIMES.

- CONNECT your machine ONLY to the matched and specified power source.
- WEAR, RESPIRATORS, HEARING PROTECTION and SAFETY SHOES when operating heavy machinery.
- Always wear safety glasses.
- DO NOT wear loose clothing or jewelry when operating machinery.
- A Safe Environment is important. Keep the area free of dust, dirt and other debris in the immediate vicinity of the machine.
- BE ALERT! Do Not Use prescription or other drugs that may affect your ability or judgment to safely use this machine.
- DISCONNECT the power source when changing tool bits and or any equipment.
- NEVER leave an operating tool unattended.
- ALWAYS keep tools, knives or bits sharp and properly aligned.
- ALWAYS keep all safety guards in place and ensure their proper function.
- ALWAYS make sure that any tools used for adjustments are removed before operating the machine.
- ALWAYS secure your work with the appropriate clamps or vises.
- ALWAYS keep bystanders safely away while operating machinery.
- DO NOT change speed while spindle is running.
- THINK SAFELY. WORK SAFELY.
- Never attempt a procedure if it dose not feel safe or comfortable.

I N D E X

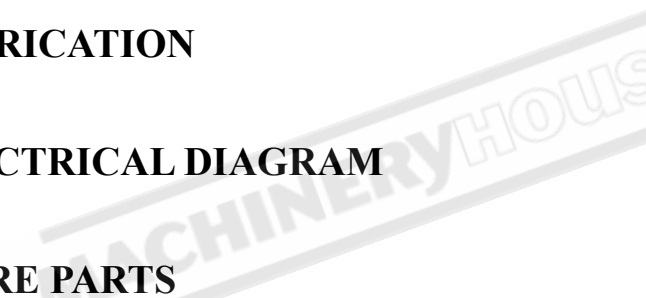
- 1、 STRUCTURE, FEATURES AND USAGE**
 - 2、 MAIN SPECIFICATIONS**
 - 3、 TRANSMISSION SYSTEM**
 - 4、 INSTALLATION AND TRIAL RUNNING**
 - 5、 OPERATION AND MAINTENANCE**
 - 6、 LUBRICATION**
 - 7、 ELECTRICAL DIAGRAM**
 - 8、 SPARE PARTS**
- 

1、 STRUCTURE, FEATURES AND USAGE

This lathe adopts full gear transmission with great stability and high tooling accuracy. The main spindle speed changing and longitudinal/cross feeding safety unit are own patented.

The full functioned lathe with longitudinal/cross auto-feeding can do spindle speeds chosen. And regular threads setting through feed box.

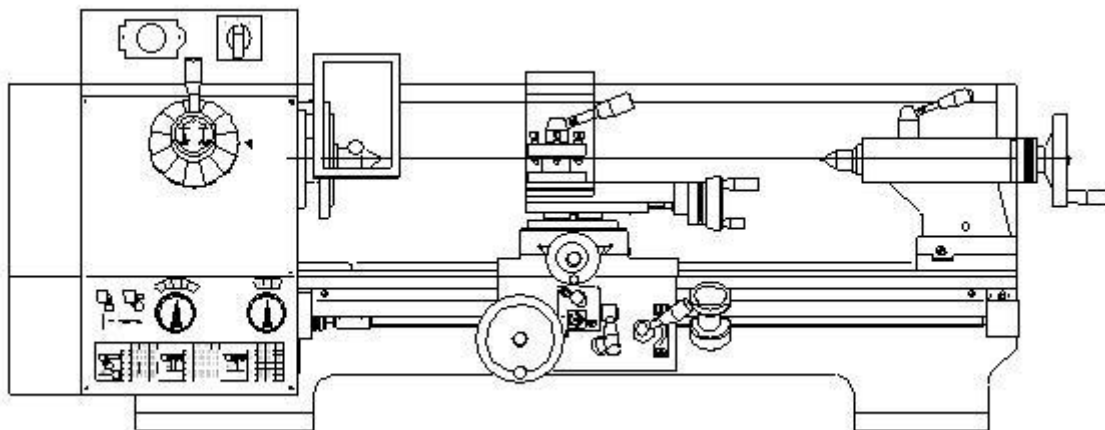

Picture 1 OVERVIEW

- ☞ Headstock Full gear driven, the spindle speed changing is achieved through sliding gears and the main spindle can get 12 kinds of speeds at wide range. The lathe has the structure of forward/reward feeding unit which can get auto feeding in both direction and make right/left threading.
- ☞ Gearbox Transmit the movement in headstock to feeding box through change gears. By choosing different change gears, different metric threading can be achieved.
- ☞ Feeding box It has 15 shifts. There is no need of changing the gears to get 15 kinds of feeding speed and tooling 15 kinds of metric threads.
- ☞ Carriage It has longitudinal/cross feeding interlock unit which can make auto feeding in longitudinal or cross direction.

Note: Feed lever MUST be Pulled to the Right to disengage safety lock before moving it up or down to engage feed as required

- ☞ The bed way adopts two V guide ways, ensuring perfect positioning accuracy and excellent tooling rigidity.
- ☞ Tailstock It adopts rapid cam-lock unit to make easy and rapid operation.
- ☞ Standard accessories Three jaw chuck, dead center, toolpost wrench, inner hexagon spanner, stud dead spanner, change gears, splash guard
- ☞ Optional accessories for your choice Machine stand, steady rest, follow rest, oil tray, tool cutter set, live center, face plate, four jaw chuck, back plate,

2、MAIN SPECIFICATIONS

Main parameters	BL250G	
Max. swing over bed	250 mm	
Max. work-piece length	500 mm	
Max. swing over carriage	150 mm	
Main spindle diameter	26 mm	
Main spindle taper	No.4	
Main spindle speed rpm	12	80—1600
Max. travel cross of toolpost	130 mm	
Max. travel longitudinal of toolpost	75 mm	
Thread in metric	15	
Range of thread in metric	0.25—2.5 mm	
Toolpost longitudinal feeding per spindle rotation	0.03—0.275mm/r	
Toolpost cross feeding per spindle rotation	0.015—0.137mm/r	
Max. travel of tailstock sleeve	60mm	
Tailstock sleeve taper	No.3	
Main motor	750W/240V/50HZ	
Gross/net weights	180/163 kg	
Overall dimensions	1130×550×405	
Packing dimensions	1200×620×600	

3、TRANSMISSION

☞ Headstock spindle speed change:

The motor power is transferred to Headstock axle I through V-belts and then to headstock main spindle through sliding gears on axle I and axle V, so the main spindle gets 12 kinds of different speeds.

☞ Feeding speed change and thread tooling:

The main spindle works on the gears on axle III and IV through feeding gears, the different meshing of sliding gears on axle III achieves forward and reverse rotation. Through a set of final reduction gear and change gears A, B, C to drive the input axle in feeding box, then through complex gears on second motion shaft, to make the output axle achieve two different rotation directions and 15 different feeds reach the carriage through longitudinal feeding screw. By pressing the half nut handle, the toolpost shall make the thread tooling; release it, the toolpost shall stop

4、 ASSEMBLING AND TRIAL

- ☞ Open the case, check the content against the packing list.
- ☞ Put the lathe on the machine stand, fasten it after adjusting the guide way to level.
- ☞ Clean the guide way, work table, carriage and oily surface with WD-40, or non-corrosive kerosene;

Inject machine lubrication oil into the parts as per lathe lubrication requirements and check the oil level in headstock and feedbox under it

- ☞ Check the longitudinal and cross movement of toolpost.
- ☞ Check the motor and electrical parts and make sure of reliable earthing.
- ☞ For trial, run the lathe at low speed in twenty minutes. During normal running, increase the speed step by step as per the speed indication shown on the speed plate. The speed change should be effected only when the main spindle fully stops. Slightly rotate the main spindle when tripping the speed change handle to help the gears smoothly changing.
- ☞ The operator shall read carefully the manual, pay attention to the lubrication and maintenance of the lathe to prolong the working life.

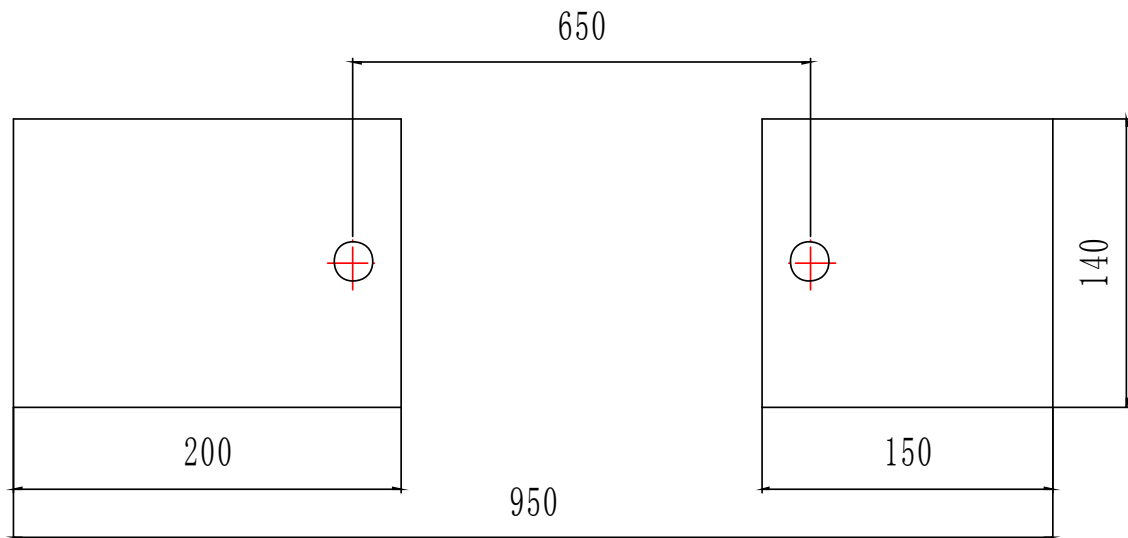

Pic. 3、 Assembly positions of the lathe

5、 OPERATION AND MAINTENANCE

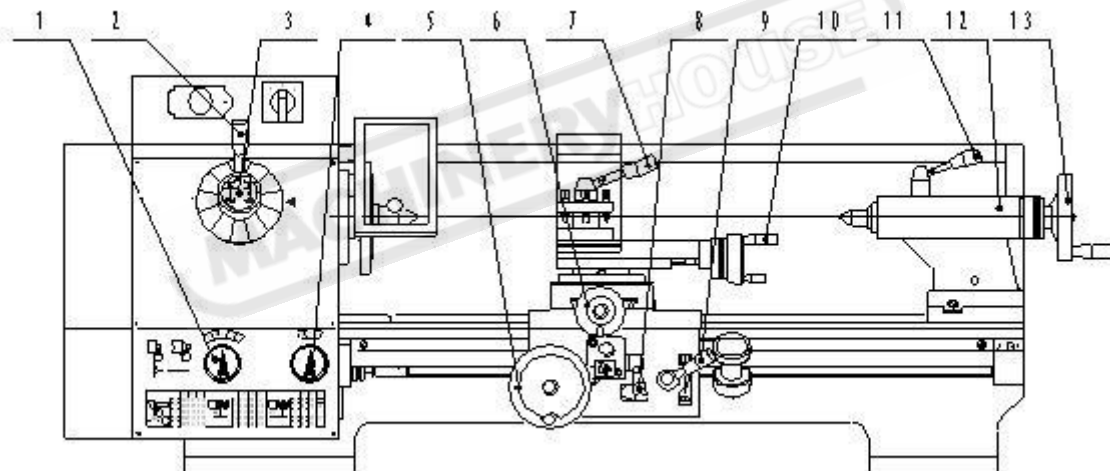

Pic 4、 Operation system

- Operation:

- ☞ Headstock:

Trip handle 2, making the arrow aiming at the tablet, shows the chosen speed.

Handle 3 is forward/reverse feeding handle, the toolpost shall move as per shown.

☞ Feeding box:

Change the position of handles 1 and 4 to get necessary threads as per the indication shown on the Metric only Feeding & Threading Table.

mm		A	B	C	mm		A	B	C
1	0.035	0.07	0.175	1	0.25	0.50	1.25		
2	0.045	0.09	0.225	2	0.30	0.60	1.50		
3	0.05	0.10	0.25	3	0.35	0.70	1.75		
4	0.06	0.12	0.30	4	0.40	0.80	2.00		
5	0.075	0.15	0.375	5	0.50	1.00	2.50		

Pic 5、 Feeding & Threading Table

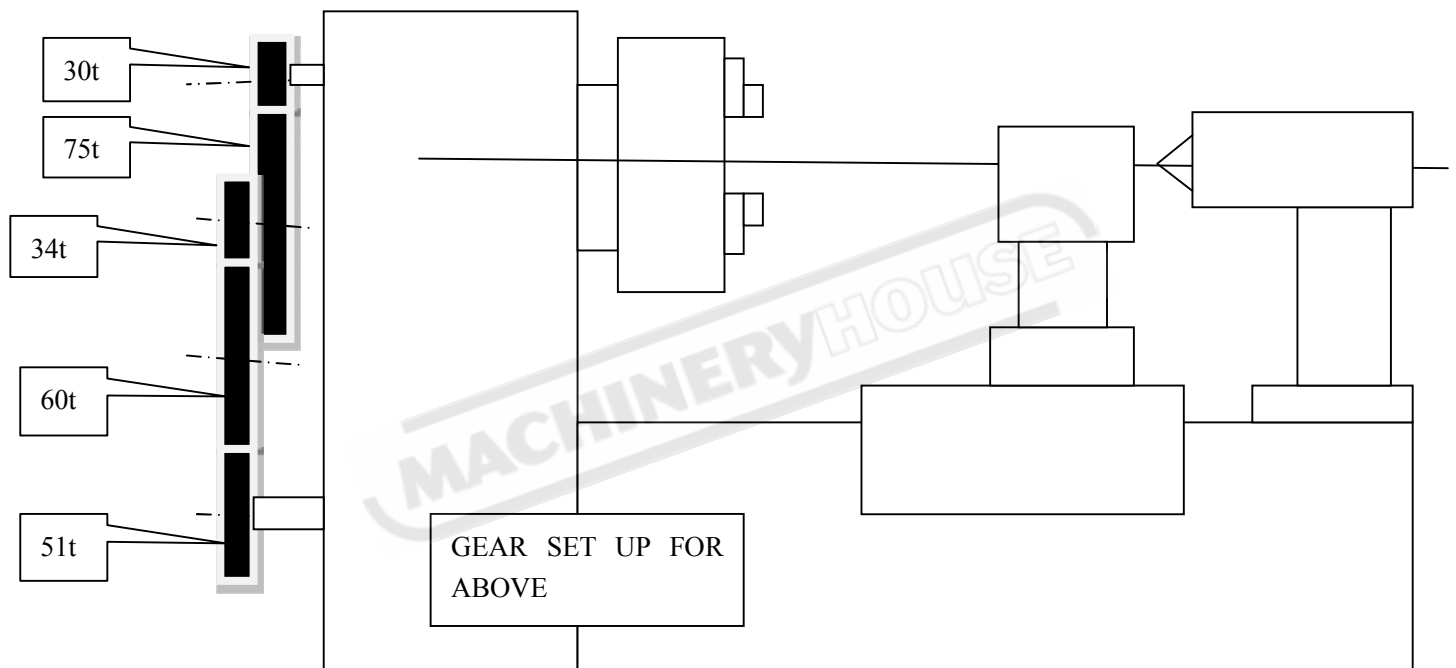

☞ Carriage:

Handle 8 is for longitudinal and cross feeding. Press down for cross feeding and up for longitudinal, the middle is neutral position. When handle 8 at neutral position, rotate handwheel 5 and 6 can also achieve longitudinal/cross movement of toolpost. Press down handle 9, close the half nut, the toolpost shall make threading. Handle 8 and 9 are inter-locked not to engage at the same time.

☞ Saddle and toolpost:

Handle 7 is for locking the toolpost, handle 10 is for moving the small carriage and handle 6 for moving working table.

☞ Tailstock:

Handle 11 is for locking the sleeve in tailstock. Releasing handle 11, rotate handle 13, you can get out sleeve; handle 12 is for locking the tailstock.

● Maintenance:

- ☞ Making lubrication as per request before operation.
- ☞ Clean the chips on bed way, saddle, toolpost to avoid strain.
- ☞ The operator shall strictly make the operation as per regulations to avoid damage of the lathe and human safety.
- ☞ Never stop/brake the lathe by hands.
- ☞ No setting of tools and other objects on the headstock, toolpost and guide way.

6、 LUBRICATION

Serial	Parts	Lub. parts	Means	Oil type	Lub. Period
1	Change gear box	Change gears, oil windows	Oil gun	Machine oil	Once per shift
2	Headstock	Gears, bearings	splash		60 days
3	Feeding box		Oil rope		Once per shift
4	toolpost	Leadscrew, guideway	Oil gun		
5	Worktable				
6	bedway				
7	Tailstock				

☞ Before and after operation, all the lubrication points and surface should be oiled.

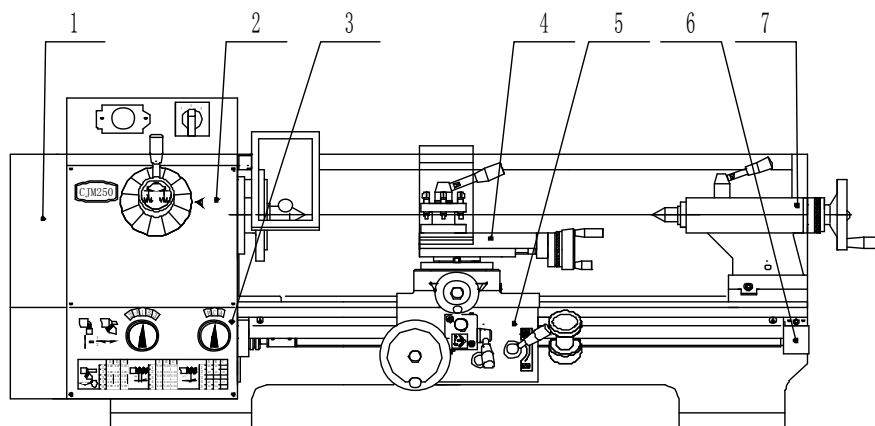

Pic 6、 Lubrication

7、 Electrical chart

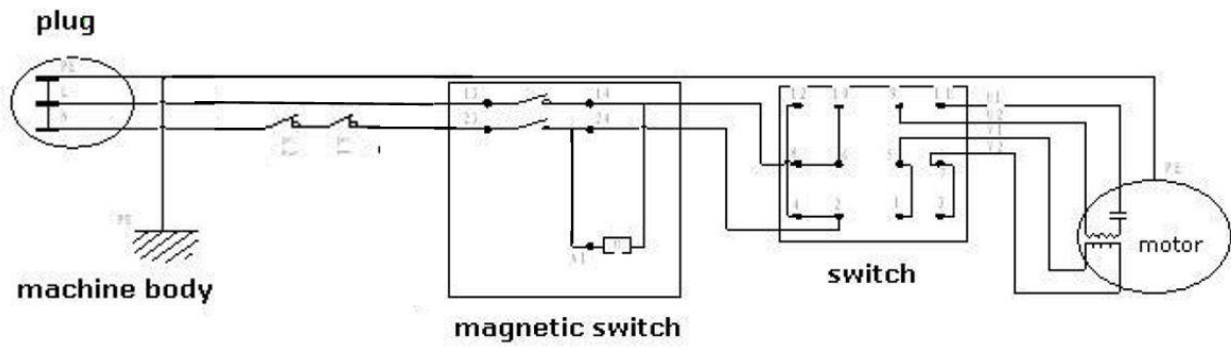

8、 ACCESSORIES

NO	Name	Specifications	Quantity
1	3 jaw chuck	φ 130	1
2	Dead centers	MT3 [#] , MT4 [#]	1 each
3	Toolpost wrench		1
4	Allen wrench	4、 5、 6	1 each
5	Stud dead spanner	12-14, 17-19	1 each
6	Change gears		30, 75,34,60,51 Tooth, on lathe
7	Splash guard		1

BED ASSEMBLY

No.	Code	Description	Specifications	Quantity	Remark
1	GB5781-86	Hexagon bolt	M8×25	4	
2	GB1171-74	V belt	O# 630	2	
3	CJM250-08-003	Motor pulley		1	
4	GB78-85	Screw	M6×10	1	
5	GB1096-79	Flat key	4×24	1	
6	CO ₂ 7124	Motor	750W/220V	1	
7	GB70-85	Screw	M6×20	2	
8	CJM250-08-004	Adjust rack		1	
9	GB97.2-85	Washer	12	2	
10	CJM250-08-010	Motor bottom plate		1	
11	GB/T91-2000	Split pin	3.2×20	2	
12	CJM250-08-012	Support axle		1	
13	GB70-85	Screw	M6×20	2	
14	CJM250-08-011	Support		1	
15	GB93-87	Spring washer	8	3	
16	GB5781-86	Hexagon bolt	M8×30	3	
17	GB5781-86	Hexagon bolt	M8×30	1	
18	GB96-85	Large washer	8	1	
19	CJM250-01-001	Bedway		1	
20	GB95-2002	Washer	12	1	
21	GB5781-86	Hexagon bolt	M12×35	2	※
22	GB117-85	Taper pin	4×24	4	
23	GB70-85	Screw	M5×16	6	
24	CJM250-01-003	Spline		2	
25	GB831-1988	slotting headless screw	M8×16	1	
26	GB/T7940.4-1995	Oil cup	8	1	
27	CJM250-01-005	Longitudinal screw base		1	
28	GB117-85	Taper pin	3×22	2	
29	GB70-85	Screw	M5×16	2	
30	CJM250-01-004	Splash guard		1	
31	GB818-85	Screw	M5×8	3	
32	CJM250-01-002	Longitudinal leadscrew		1	

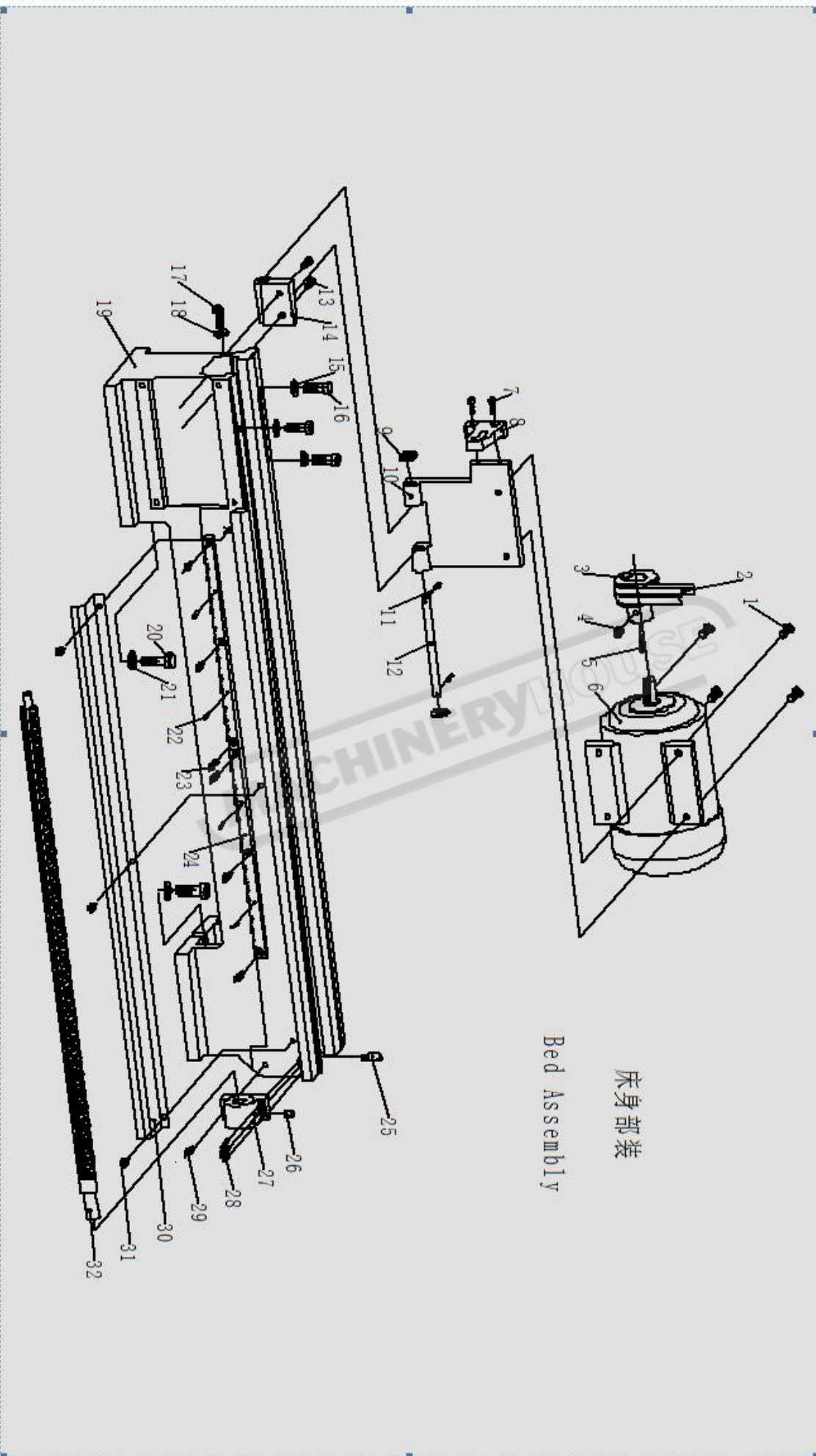

HEADSTOCK ASSEMBLY

No.	Code	Description	Specifications	Quantity	Remark
1	CJM250-02-022	Plug		1	
2	GB276-89	Bearing	102	1	
3	CJM250-02-028	Triple gear		1	
4	CJM250-02-034	Dual gear		1	
5	GB70-85	Screw	M6×16	4	
6	CJM250-02-048	Headstock cover		1	
7	CJM250-02-048	Oil plug		1	
8	CJM250-02-035	Spline shaft		1	
9	GB276-89	Bearing	102	1	
10	CJM250-02-022	Plug		1	
11	CJM250-02-022	Plug		1	
12	GB276-89	Bearing	102	1	
13	CJM250-02-023	Waher		1	
14	CJM250-02-024	Gear		1	
15	CJM250-02-026	Spacer bush		1	
16	CJM250-02-027	Gear		1	
17	CJM250-02-026	Spacer bush		1	
18	CJM250-02-030	Gear		1	
19	CJM250-02-031	Gear		1	
20	CJM250-02-032	Sahft		1	
21	GB1096-79	Flat key	6×75	1	
22	GB1096-79	Flat key	5×10	1	
23	CJM250-02-033	Gear		1	
24	GB276-89	Bearing	102	1	
25	CJM250-02-022	Plug		1	
26	GB5781-2000	Bolt	M8×25	3	
27	CJM250-02-043	Left fork		1	
28	CJM250-02-047	Right fork		1	
29	CJM250-02-051	Fork axle		1	
30	CJM250-02-050	Seal		1	
31	GB78-85	Screw	M6×12	1	
32	CJM250-02-001	Headstock body		1	
33	GB872-88	Round nut	M35×1.5	1	
34	GB858-88	Detent ring	35	1	
35	GB70-85	Screw	M6×12	3	

No.	Code	Description	Specifications	Quantity	Remark
36	CJM250-02-017	Back oil seal cover		1	
37	CJM250-02-016	Oil retainer		1	
38	GB297-84	Bearing	7207	1	
39	GB894. 1-86	Spindle elastic collar	35	1	
40	CJM250-02-018	Dual gear		1	
41	GB894. 1-86	Spindle elastic collar	38	1	
42	CJM250-02-036	Dual gear		1	
43	GB297-84	Bearing	7208	1	
44	CJM250-02-037	Oil cover		1	
45	GB70-85	Screw	M6×12	3	
46	CJM250-02-015	Main spindle		1	
47	GB1096-79	Flat key	10×30	1	
48	GB1566-79	Flat key	10×40	1	
49	GB872-88	Round nut	M20×1.5	1	
50	GB858-88	Block ring	20	1	
51	CJM250-02-019	Input pulley		1	
52	GB70-85	Screw	M6×12	3	
53	CJM250-02-021	Bearing seat		1	
54	HG4-692-67	Oil seal	PC25×42×10	1	
55	CJM250-02-020	Isolation ring		1	
56	GB276-89	Bearing	104	1	
57	GB893-86	Hole elastic collar	42	1	
58	GB276-89	Bearing	104	1	
59	GB1160-79	Round oil window	16R51-5A	1	
60	CJM250-02-042	Sliding block		1	
61	GB882-86	Pin	5×14	1	
62	CJM250-02-041	Sliding coat		1	
63	CJM250-02-046	Upper fork plate		1	
64	GB119-86	Pin	10×26	1	
65	GB1096-79	Flat key	6×18	1	
66	CJM250-02-025	Input axle		1	
67	CJM250-02-029	Dual gear		1	
68	GB276-89	Bearing	102	1	
69	CJM250-02-022	Plug		1	
70	CJM250-02-002	Fork support axle		1	
71	CJM250-02-045	Lower fork		1	
72	GB894. 1-86	Spindle elastic collar	15	1	

No.	Code	Description	Specifications	Quantity	Remark
73	GB119-86	Pin	10×26	1	
74	CJM250-02-044	Lower fork plate		1	
75	CJM250-02-041	Sliding coat		1	
76	GB882-86	Pin	5×14	1	
77	CJM250-02-042	Sliding block		1	
78	CJM250-02-058	Fork arm		1	
79	GB879-86	Elastic column pin	3×22	1	
80	JB892-77	Complex washer	10	1	
81	GB5783-2000	Bolt	M10×10	1	
82	CJM250-02-059	Prod block		1	
83	CJM250-02-042	Slide block		1	
84	CJM250-02-057	Fork shaft		1	
85	GB70-85	Screw	M5×8	2	
86	CJM250-02-040	Fork rod		1	
87	CJM250-02-041	Sliding coat		1	
88	CJM250-02-052	Endface curve groove		1	
89	GB882-86	Pin	5×14	1	
90	CJM250-02-039	Nest		1	
91	GB1096-79	Flat key	6×18	1	
92	CJM250-02-053	Shaft sleeve		1	
93	GB819-85	Screw	M4×10	3	
94	GB93-85	Elastic washer	3	1	
95	CJM250-02-054	Handleset support		1	
96	CJM250-02-038	Screw shaft		1	
97	GB819-85	Screw	M5×12	3	
98	CJM250-03-004	Handleset rod		1	
99	CJM250-02-055	Speed plate		1	
100	GB308-77	Steel ball	6	1	
101	GB2089-80	Spring	0.8×6×15	1	
102	GB73-85	Screw	M8×10	1	
103	GB77-85	Screw	M6×10	2	
104	CJM250-02-056	Round handle		1	
105	GB894.1-86	Spindle elastic collar	24	1	
106	CJM250-02-009	Shaft		1	
107	CJM250-02-004	Gear		1	
108	CJM250-02-005	Coat		1	
109	GB894.1-86	Spindle elastic collar	18	1	

No.	Code	Description	Specifications	Quantity	Remark
110	GB896-86	Open gasket	9	1	
111	CJM250-02-014	Gear		1	
112	GB70-85	Screw	M6×12	2	
113	CJM250-02-011	Axle coat		1	
114	HG4-692-67	Oil seal	PC15×24×7	1	
115	CJM250-02-012	Coat		1	
116	GB1096-79	Flate key	4×10	1	
117	CJM250-02-013	Spline shaft		1	
118	CJM250-02-010	Slip gear		1	
119	GB2089-80	Spring	0.8×5×15	1	
120	GB308-77	Steel ball	5	1	
121	CJM250-02-003	Bush		1	
122	GB1155-79	Oil cup	6	1	
123	GB896-86	Open gasket	9	1	
124	GB97-85	Gasket	12	1	
125	CJM250-08-009	Exchange gear		1	
126	CJM250-02-007	Gear		1	
127	CJM250-02-008	Key collet		1	
128	GB1096-79	Flat key	6×18	1	
129	CJM250-02-006	Small axle		1	

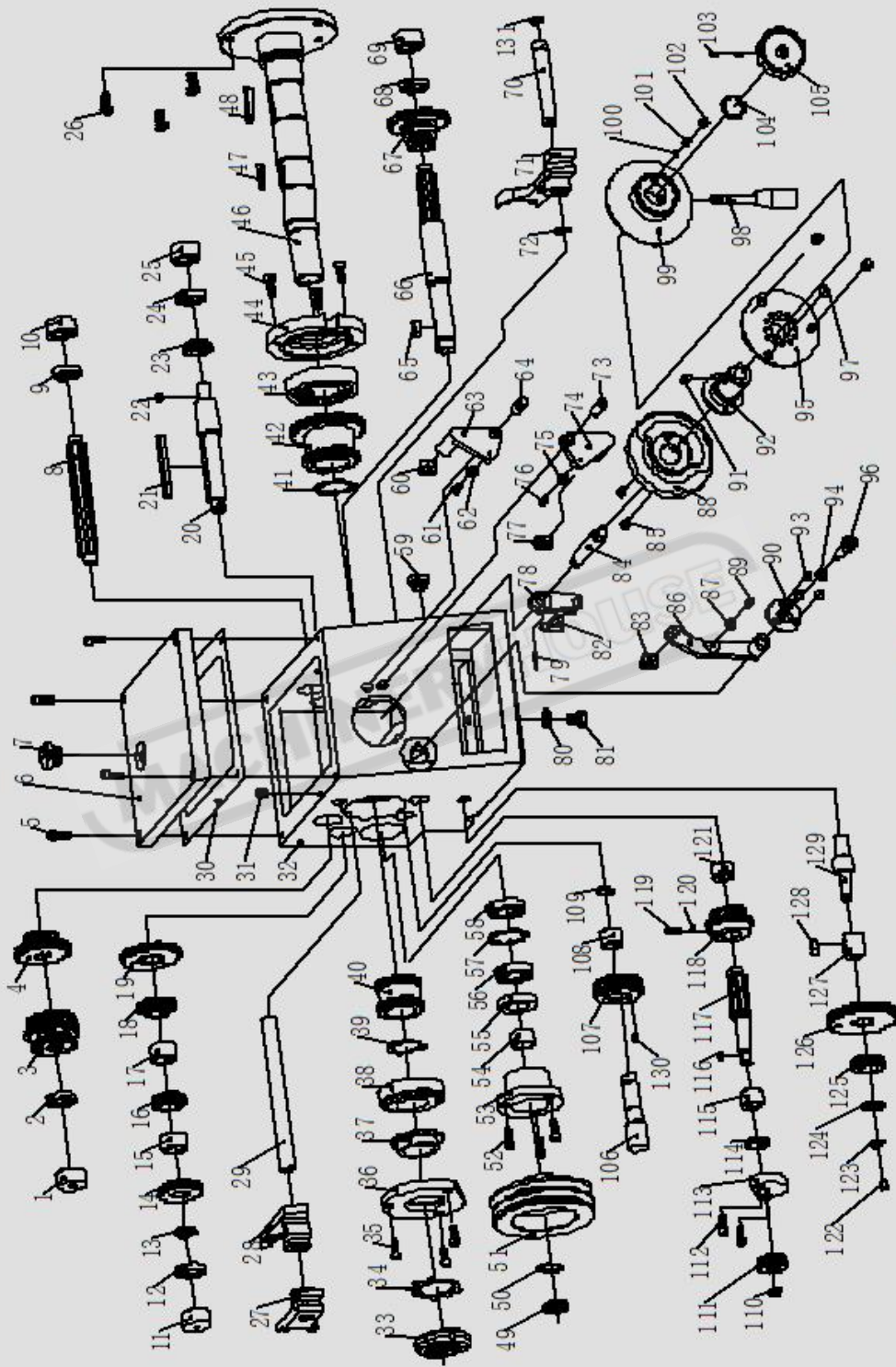

床头箱部装

Headstock Assembly

TAILSTOCK ASSEMBLY

No.	Code	Description	Specifications	Quantity	Remark
1	CJM250-03-004	Handle		1	
2	CJM250-03-003	Locking handle		1	
3	CJM250-03-012	Washer		1	
4	CJM250-03-013	Locking collet		1	
5	CJM250-03-014	Locking nut		1	
6	GB/T7940.4-1995	Oil cup	6	1	
7	GB/T879-2000	Elastic column pin	3×22	1	
8	GB/T77-2000	Screw	M10×35	1	
9	CJM250-03-002	Tailstock		1	
10	J31-3A	T type key	B5×12	1	
11	GB73-85	Screw	M4×12	2	
12	CJM250-03-006	Nut		1	
13	CJM250-03-001	Tailstock sleeve		1	
14	CJM250-03-011	Long handle		1	
15	CJM250-03-016	Eccentric shaft		1	
16	GB/T879-2000	Elastic column pin	3×22	1	
17	GB/T79-2000	Screw	M5×8	2	
18	GB/T77-2000	Screw	M10×35	1	
19	GB/T78-2000	Screw	M10×16	1	
20	CJM250-03-005	Screw		1	
21	GB1096-79	Flat key	4×20	1	
22	CJM250-03-007	Fixation base		1	
23	GB/T7940.4-1995	Oil cup	6	1	
24	GB70-85	Screw	M5×16	4	
25	CJM250-04-012a	Dial gauge		1	
26	CJM250-03-008	Handwheel		1	
27	GB/T96.1-2002	Large washer	10	1	
28	GB/T41-2000	Hexagon nut	M10	1	
29	CJM250-03-010	Handle coat		1	
30	CJM250-03-009	Handle rod		1	
31	GB/T2089-1994	Spring	0.5×3×12	1	
32	GB308-77	Steel ball	4	1	
33	CJM250-03-020	Positioning block		1	
34	GB70-85	Screw	M5×10	1	
35	CJM250-03-015	Positioning axle		1	

No.	Code	Description	Specifications	Quantity	Remark
36	CJM250-03-020	Positioning block		1	
37	GB70-85	Screw	M5×10	1	
38	GB/T894. 1-1986	Spindle elastic collar	15	1	
39	CJM250-03-017	Draw bar		1	
40	CJM250-03-018	Tailstock bottomplate		1	
41	CJM250-03-019	Clamp		1	
42	GB/T41-2000	Hexagon nut	M10	2	

MACHINERYHOUSE

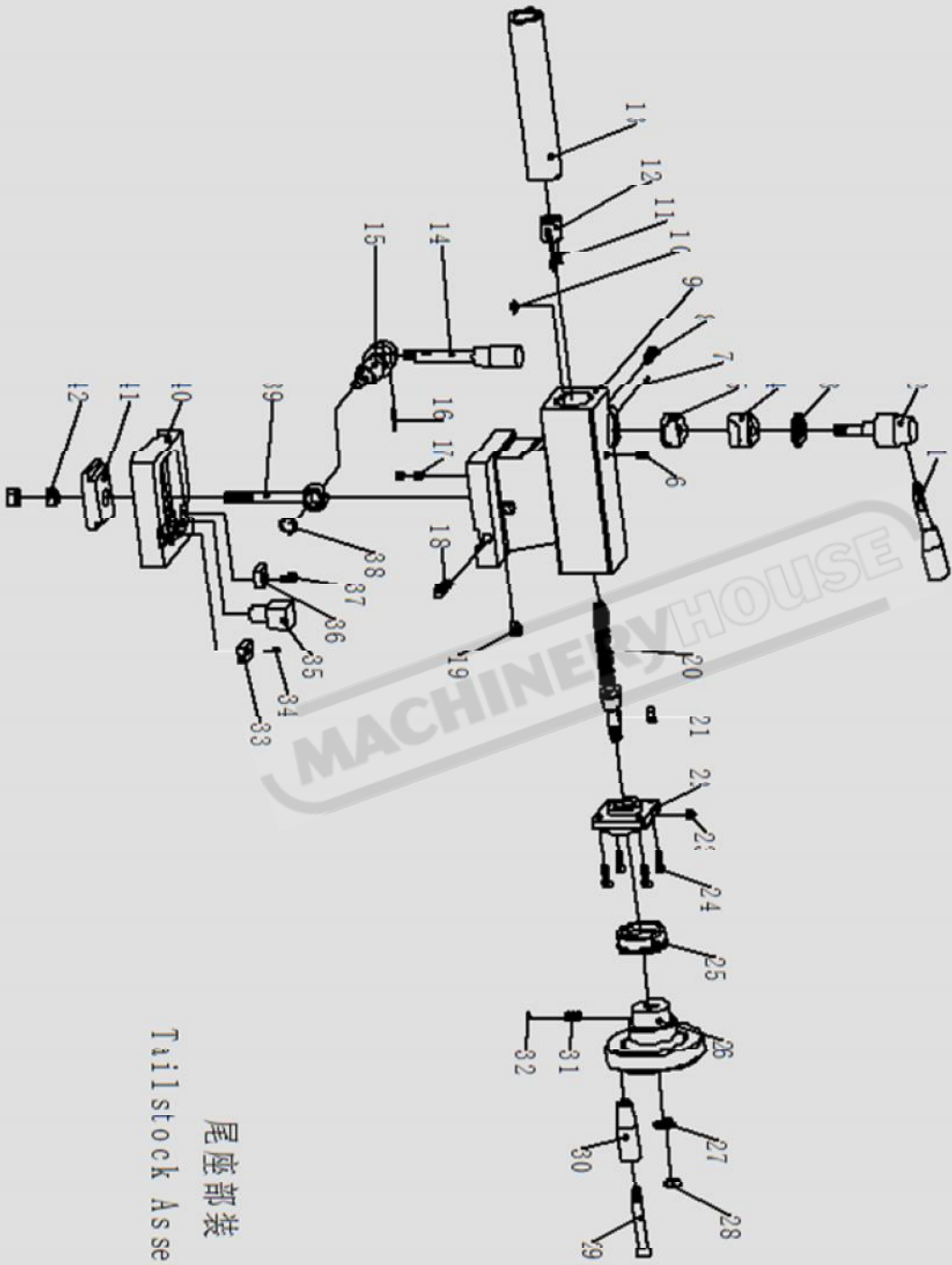

尾座部装
Tailstock Assembly

TOOLPOST ASSEMBLY

No.	Code	Description	Specifications	Quantity	Remark
1	CJM250-03-004	Handle		1	
2	CJM250A-04-008	Handle seat		1	
3	CJM250A-04-006	Wahser		1	
4	GB85-1988	Fixationo screw	M8×30	8	
5	CJM250A-04-005	Tool seat		1	
6	CJM250A-04-004	Positioning pin		1	
7	GB/T2089-1994	Spring	0.8×4×15	1	
8	CJM250A-04-003	Small carriage		1	
9	CJM250A-04-012	Small wedge		1	
10	CJM250A-04-007	T type bolt		1	
11	GB71-1985	Groovetaper end screw	M5X16	2	
12	GB/T41-2000	Hexagon nut	M5	2	
13	GB/T70. 1-2000	Inner hexagon screw	M5X10	1	
14	GB/T7940. 4-1995	Oil cup	6	1	
15	CJM250A-04-011	Support		1	
16	GB/T7940. 4-1995	Oil cup	6	1	
17	GB/T70. 1-2000	Inner hexagon screw	M6×16	2	
18	CJM250-04-012	Dial gauge		1	
19	CJM250-04-013	Dual handle		1	
20	CJM250-04-019	Cushion		1	
21	GB/T77-2000	Inner hexagon screw	M6×6	2	
22	GB/T819-2000	Cruciform sunk screw	M6×16	1	
23	CJM250-04-014	Handle coat		1	
24	CJM250-04-015	Handle rod		1	
25	CJM250-04-021	Handle rod		1	
26	CJM250-04-020	Handle coat		1	
27	GB/T2089-1994	Spring	0.5×3×12	1	
28	GB308-77	Steel ball	4	1	
29	GB1096-79	Flat key	4×20	1	
30	CJM250A-04-010	Small screw		1	
31	CJM250A-04-009	Small nut		1	
32	GB/T41-2000	Hexagon nut	M6	2	
33	GB95-2002	Gasket	6	2	
34	CJM250A-04-001	Sliding base		1	

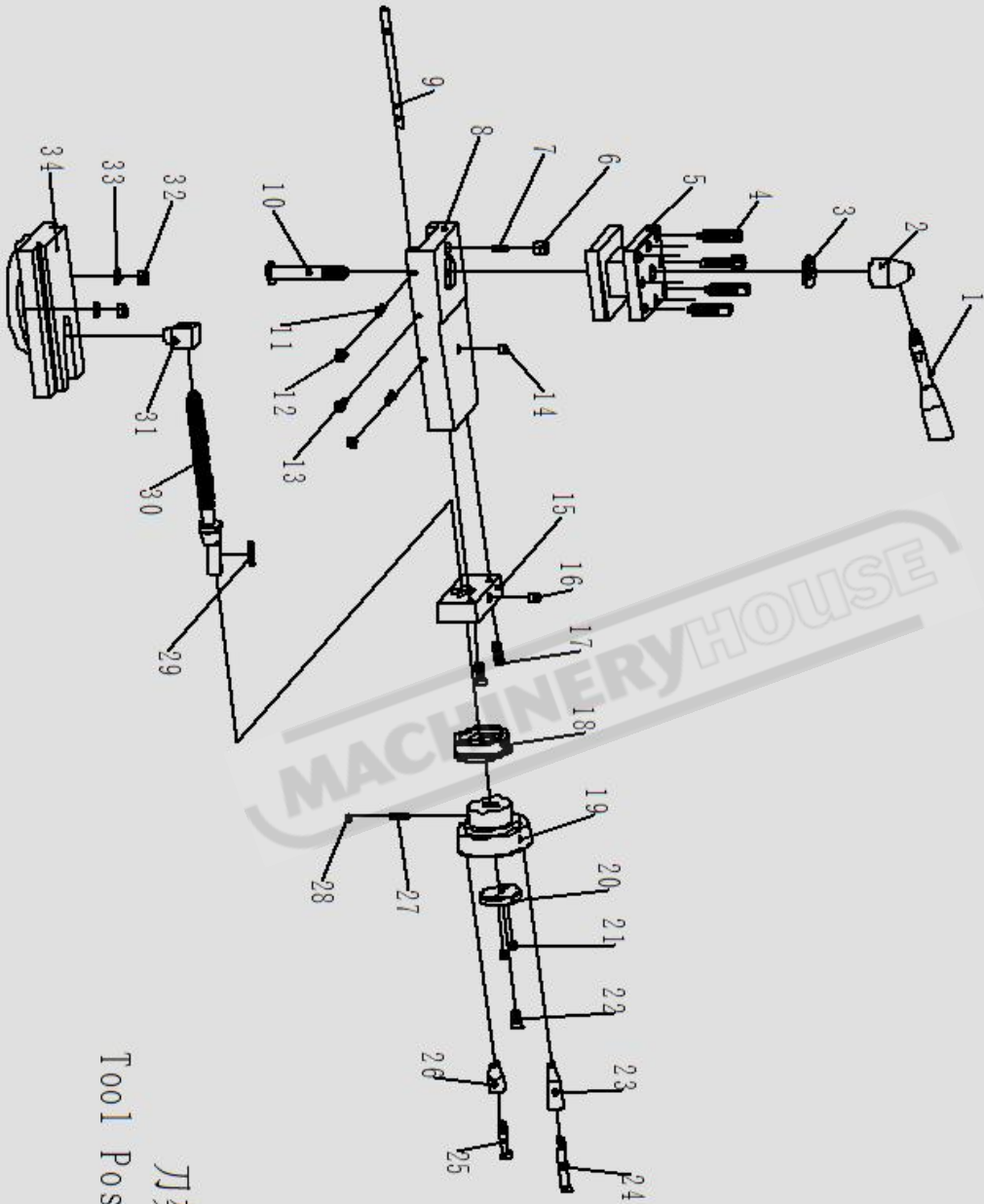

刀架部裝
Tool Post Assembly

SADDLE AND CROSS SLIDE ASSEMBLY

No.	Code	Description	Specifications	Quantity	Remark
1	GB/T818-2000	Cruciform pan head screw	M6X12	2	
2	CJM250A-05-003	Saddle splash guard		1	
3	GB/T70-2000	Inner hexagon screw	M6×20	1	
4	GB/T7940.4-1995	Oil cup	6	3	
5	CJM250A-05-002	Saddle		1	
6	GB71-85	Groove taper end screw	M5×30	4	
7	GB6172-86	Nut	M5	4	
8	GB/T70-2000	Inner hexagon screw	M5×25	1	
9	CJM250A-05-004	Wedge		1	
10	GB37-1988	T type groove bolt	M6×25	2	
11	CJM250A-05-001	Central spindle		1	
12	GB71-85	Groove taper end screw	M5×10	1	
13	GB818-85	Cruciform pan head screw	M5×8	2	
14	CJM250-05-016	Back scrapper		1	
15	CJM250-05-009	Nut		1	
16	GB/T7940.4-1995	Oil cup	6	1	
17	GB/T7940.4-1995	Oil cup	6	1	
18	CJM250-05-012	Apron		1	
19	CJM250-05-016	Back scrapper		1	
20	GB/T70-2000	Inner hexagon screw	M5×35	1	
21	GB818-85	Cruciform pan head screw	M5×8	2	
22	GB818-85	Cruciform pan head screw	M5×8	2	
23	CJM250-05-014	Front left scrapper		1	
24	CJM250-05-013	Clamp		1	
25	GB/T70-2000	Inner hexagon screw	M5×30	8	
26	CJM250-05-013	Clamp		1	
27	CJM250-05-018	Locking block		1	
28	GB/T7940.4-1995	Oil cup	6	1	
29	GB/T7940.4-1995	Oil cup	6	1	
30	CJM250-05-015	Front right scrapper		1	
31	GB818-85	Cruciform pan head screw	M5×8	2	
32	GB/T879-2000	Elastic column pin	4×20	1	
33	CJM250-05-007	Gear		1	
34	CJM250-05-006	Cross leadscrew		1	
35	GB1096-79	Flat key	4×20	1	

No.	Code	Description	Specifications	Quantity	Remark
36	CJM250-05-005	Leadscrew base		1	
37	GB/T7940.4-1995	Oil cup	6	1	
38	GB/T70-2000	Inner hexagon screw	M5×20	2	
39	CJM250-05-004a	Dial gauge		1	
40	GB308-77	Steel ball	4	1	
41	GB/T2089-1994	Spring	0.5×3×12	1	
42	CJM250-05-003	Handwheel		1	
43	CJM250-04-001	Handle coat		1	
44	CJM250-04-002	Handle rod		1	
45	CJM250-04-019	Cushion		1	
46	GB/T77-2000	Inner hexagon screw	M6×6	2	
47	GB/T819-2000	Cruciform sunk screw	M6×16	1	

MACHINERYHOUSE

床鞍部装
Saddle and Cross Slide Assembly

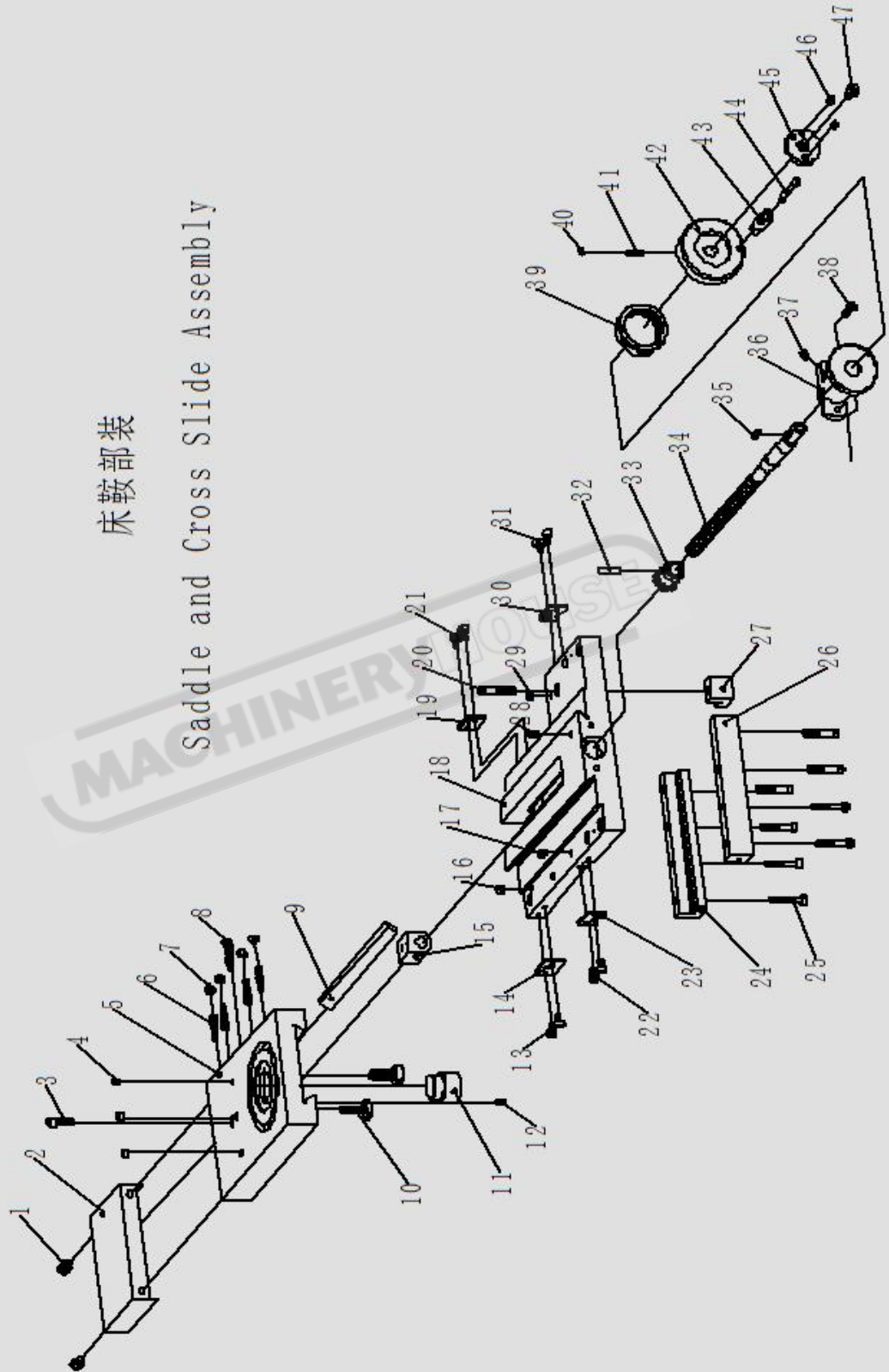

APRON ASSEMBLY

No.	Code	Description	Specifications	Quantity	Remark
1	CJM250-06-001	Wedge		1	
2	CJM250-06-023	Half nut		1	
3	CJM250-06-024	Half nut seat		1	
4	GB119-86	Column pin	6×14	1	
5	GB/T819-2000	Screw	M4×10	1	
6	CJM250-06-028	Axle		1	
7	CJM250-06-016	Coat		1	
8	CJM250-06-015	Spline gear		1	
9	GB/T819-2000	Screw	M5×10	1	
10	CJM250-06-022	Gasket		1	
11	CJM250-06-025	Worm		1	
12	GB/T70-2000	Screw	M4×12	3	
13	GB/T79-2000	Screw	M6×8	1	
14	CJM250-06-013	Gear shaft		1	
15	CJM250-06-027	Key		1	
16	CJM250-06-026	Worm screw		1	
17	GB1096-79	Flat key	4×8	1	
18	GB/T70-2000	Screw	M6×25	4	
19	CJM250-06-019	Worm seat		1	
20	GB/T71-2000	Screw	M5×20	2	
21	GB117-86	Taper pin	4×30	2	
22	GB/T79-2000	Screw	M4×14	2	
23	GB6170-86	Nut	M4	2	
24	CJM250-06-028	Axle		1	
25	CJM250-06-003	Detaching axle		1	
26	GB/T879-2000	Elastic column pin	4×30	1	
27	CJM250-06-002	Limitation coat		1	
28	GB/T879-2000	Elastic column pin	4×40	1	
29	CJM250-06-004	Detaching handleseat		1	
30	CJM250-03-004	Handle		1	
31	GB308-77	Steel ball	6	1	
32	GB/T2089-1994	Spring	0.8×5×15	1	
33	GB/T73-2000	Screw	M8×8	1	
34	GB/T879-2000	Elastic column pin	3×24	1	
35	CJM250-06-021	Handle seat		1	

No.	Code	Description	Specifications	Quantity	Remark
36	CJM250-06-0	Handle		1	
37	CJM250-06-017	Gear axle		1	
38	GB/T70-2000	Screw	M5×25	2	
39	CJM250-06-020	Fork axle seat		1	
40	GB308-77	Steel ball	6	1	
41	GB/T2089-1994	Spring	0.8×5×15	1	
42	GB/T73-2000	Screw	M8×8	1	
43	CJM250-06-007	Rack shaft		1	
44	CJM250-06-029	Fork		1	
45	CJM250-06-030	Limitation rod		1	
46	GB/T879-2000	Elastic column pin	3×16	1	
47	GB1096-79	Flat key	4×12	2	
48	CJM250-06-005	Axle		1	
49	CJM250-06-018	Gear		1	
50	CJM250-06-006	Coat		1	
51	GB/T819-2000	Screw	M5×10	1	
52	CJM250-06-022	Gasket		1	
53	CJM250A-06-001	Coat		1	
54	CJM250-03-009	Handle rod		1	
55	CJM250-03-010	Handle coat		1	
56	GB6170-86	Nut	M10	1	
57	GB/T96. 1-2002	Big gasket	10	1	
58	GB308-77	Steel ball	4	1	
59	GB/T2089-1994	Spring	0.5×3×12	1	
60	CJM250-06-031	Handlewheel		1	
61	CJM250-06-009a	Dial gauge		1	
62	GB819-86	Cruciform countersunk head screw	M5×10	3	
63	CJM250-06-010	Coat		1	
64	CJM250-06-008	Gear axle		1	
65	GB1096-79	Flat key	4×30	1	
66	CJM250-06-012	Gear		1	
67	CJM250-06-014	Coat		1	

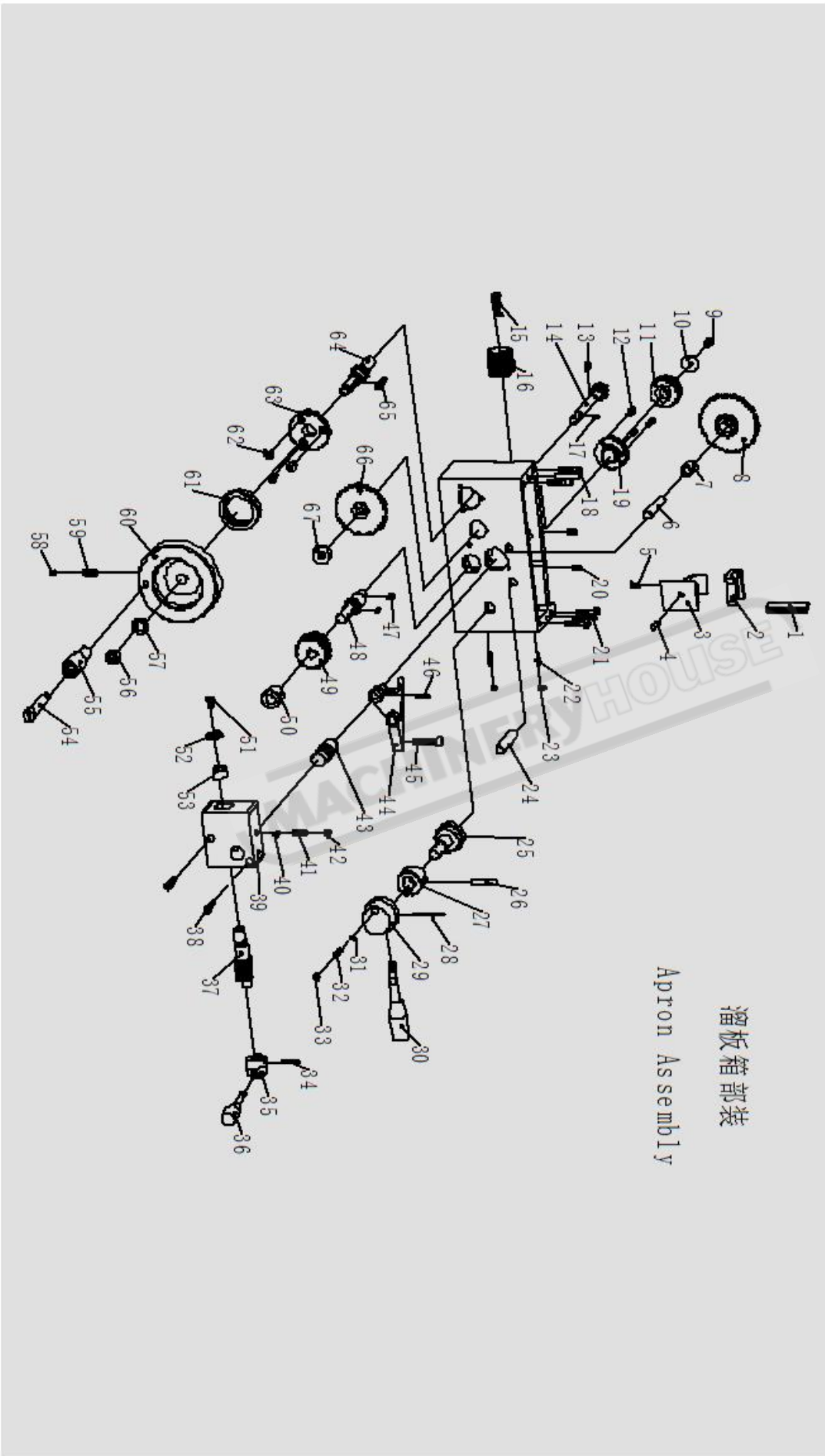

溜板箱部装

Apron Assembly

GEAR BOX ASSEMBLY

No.	Code	Description	Specifications	Quantity	Remark
1	GB/T7940.4-1995	Oil cup	6	1	
2	CJM250-07-001	Input axle		1	
3	GB1096-79	Flat key	4×80	1	
4	GB/T819-2000	Screw	M5×12	3	
5	CJM250-07-002	Supporting coat		1	
6	GB894.1-86	Axle elastic collar	12	1	
7	GB/T819-2000	Screw	M4×8	6	
8	CJM250-07-030	Cover		1	
9	CJM250-07-009	Gear box body		1	
10	CJM250-07-014	Gear		1	
11	CJM250-07-013	Gear		1	
12	CJM250-07-006	Spacer bush		1	
13	CJM250-07-007	Gear		1	
14	CJM250-07-006	Spacer bush		1	
15	CJM250-07-004	Gear		1	
16	CJM250-07-003	Gear		1	
17	CJM250-07-010	Gear shaft sleeve		1	
18	CJM250-07-011	Gear		1	
19	CJM250-07-012	Dual gear		1	
20	GB5783-2000	Bolt	M10×10	1	
21	JB892-77	complex gasket	10	1	
22	CJM250-07-015	Sleeve		1	
23	GB/T73-2000	Screw	M4×10	1	
24	GB1096-79	Flat key	4×36	1	
25	GB1096-79	Flat key	5×80	1	
26	GB1096-79	Flat key	5×25	1	
27	GB/T819-2000	Screw	M5×12	2	
28	CJM250-07-005	Left cover coat		1	
29	CJM250-07-008	Axle		1	
30	JB892-77	Complex gasket	10	1	
31	GB5783-2000	Bolt	M10×10	1	
32	GB70-85	Screw	M6×100	4	
33	CJM250-07-032	Handle		1	
34	CJM250-07-029	Handle seat		1	
35	GB879-86	Elastic columnpin	4×45	1	

No.	Code	Description	Specifications	Quantity	Remark
36	GB308-77	Steel ball	6	2	
37	GB/T2089-1994	Spring	0.8×5×15	2	
38	GB/T73-2000	Screw	M8×8	2	
39	GB879-86	Elastic columnpin	4×45	1	
40	CJM250-07-029	Handle seat		1	
41	CJM250-07-032	Handle		1	
42	CJM250-07-025	Left fork		1	
43	CJM250-07-027	Fork arm		1	
44	CJM250-07-028	Fork shaft		1	
45	CJM250-07-030	Left positioning coat		1	
46	GB/T819-2000	Screw	M5×12	2	
47	GB/T819-2000	Screw	M5×12	2	
48	CJM250-07-030	Right positioning coat		1	
49	CJM250-07-028	Fork shaft		1	
50	GB879-86	Elastic column pin	3×22	1	
51	CJM250-07-027	Fork arm		1	
52	CJM250-07-026	Right fork		1	
53	GB879-86	Elastic column pin	3×22	1	
54	GB1160-79	Round oil window	16R51-5A	1	
55	CJM250-07-016	Gear		1	
56	CJM250-07-017	Gear		1	
57	CJM250-07-018	Gear		1	
58	GB/T73-2000	Screw	M4×10	1	
59	CJM250-07-005	Right cover coat		1	
60	GB/T819-2000	Screw	M5×12	2	
61	CJM250-07-021	Output axle		1	
62	GB1096-79	Flat key	4×36	1	
63	CJM250-07-022	Gear		1	
64	CJM250-07-020	Dual gear		1	
65	CJM250-07-019	Sleeve		1	
66	GB/T301-1995	Thrust Ball Bearing	81102	1	
67	CJM250-07-023	Bearing seat		1	
68	GB70-85	Screw	M5×16	2	
69	GB/T301-1995	Thrust Ball Bearing	81102	1	
70	CJM250-07-024	Coupling band		1	
71	GB117-79	Taper pin	3×22	2	

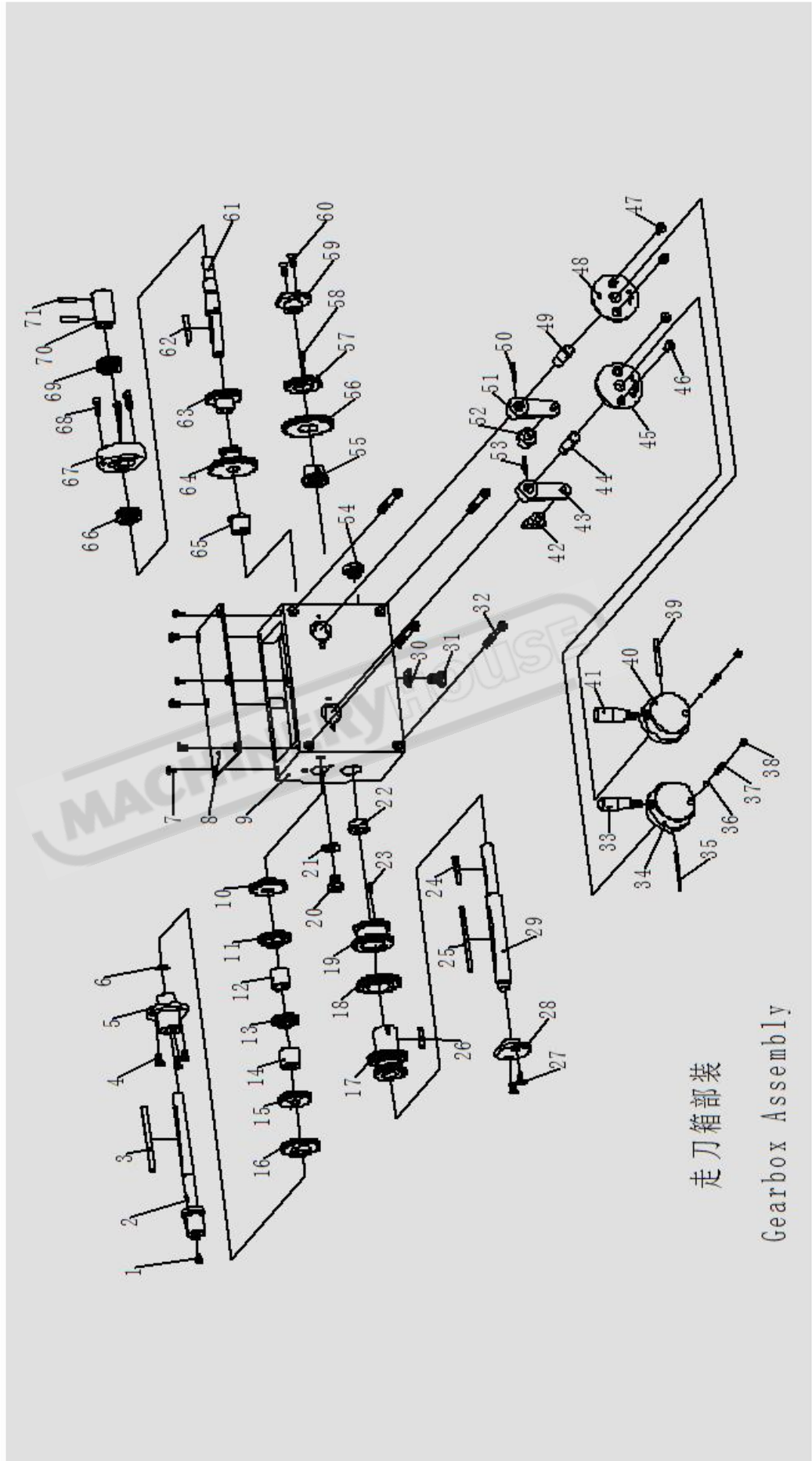

走刀箱部装

Gearbox Assembly

COMPOUND BOX

No.	Code	Description	Specifications	Quantity	Remark
1	CJM250-08-001	Compound box body		1	
2	CJM250-08-002	Compound box cover		1	
3	GB879-86	Elastic column pin	3×18	1	
4	GB70-85	Screw	M5×12	5	
5	GB4141-79	Star handle	8×32	1	A Type
6	CJM320B-08-014	Fixation coat		1	Borrowing
7	GB6170-86	Nut	M14	1	
8	CJM320B-08-016	Axle		1	Borrowing
9	GB896-86	Split damping ring	6	1	
10	CJM320B-08-015	Door knob		1	Borrowing
11	GB879-86	Elastic column pin	3×18	1	
12	GB1096-79	Flat key	6×18	1	
13	GB6170-86	Nut	M8	1	
14	CJM250-08-005	Change gear bracket		1	
15	CJM250-08-006	Axle		1	
16	GB1096-79	Flat key	6×18	1	
17	CJM250-02-008	Key coat		1	
18	CJM250-08-009	Exchange gear		1	
19	CJM250-08-008	Washer		1	
20	GB97-85	Washer	12	1	
21	GB896-86	Open washer	9	1	
22	GB/T7940.4-1995	Oil cup	6	1	
23	GB896-86	Open washer	9	1	
24	GB97-85	Washer	12	1	
25	CJM250-08-008	Washer		1	
26	CJM250-08-009	Exchange gear		1	
27	GB5781-2000	Bolt	M8×30	1	
28	GB96-85	Big gasket		1	
29	CJM250-08-007	Gasket		1	
30	CJM250-07-001	Input axle		1	

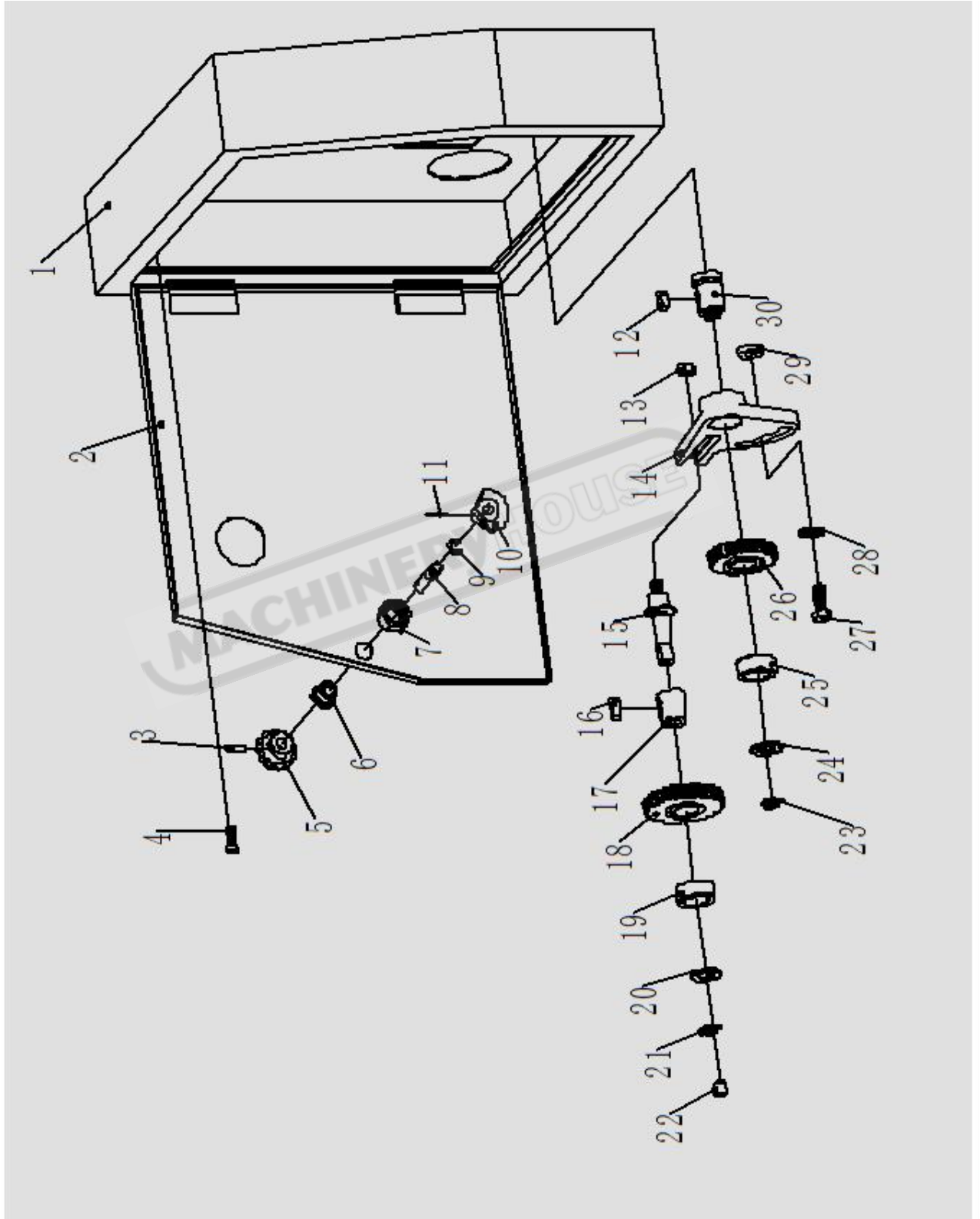



WARNING

General Machinery Safety Instructions

Machinery House
requires you to read this entire Manual before using this machine.

- 1. Read the entire Manual before starting machinery.** Machinery may cause serious injury if not correctly used.
- 2. Always use correct hearing protection when operating machinery.** Machinery noise may cause permanent hearing damage.
- 3. Machinery must never be used when tired, or under the influence of drugs or alcohol.** When running machinery you must be alert at all times.
- 4. Wear correct Clothing.** At all times remove all loose clothing, necklaces, rings, jewelry, etc. Long hair must be contained in a hair net. Non-slip protective footwear must be worn.
- 5. Always wear correct respirators around fumes or dust when operating machinery.** Machinery fumes & dust can cause serious respiratory illness. Dust extractors must be used where applicable.
- 6. Always wear correct safety glasses.** When machining you must use the correct eye protection to prevent injuring your eyes.
- 7. Keep work clean and make sure you have good lighting.** Cluttered and dark shadows may cause accidents.
- 8. Personnel must be properly trained or well supervised when operating machinery.** Make sure you have clear and safe understanding of the machine you are operating.
- 9. Keep children and visitors away.** Make sure children and visitors are at a safe distance for you work area.
- 10. Keep your workshop childproof.** Use padlocks, Turn off master power switches and remove start switch keys.
- 11. Never leave machine unattended.** Turn power off and wait till machine has come to a complete stop before leaving the machine unattended.
- 12. Make a safe working environment.** Do not use machine in a damp, wet area, or where flammable or noxious fumes may exist.
- 13. Disconnect main power before service machine.** Make sure power switch is in the off position before re-connecting.
- 14. Use correct amperage extension cords.** Undersized extension cords overheat and lose power. Replace extension cords if they become damaged.
- 15. Keep machine well maintained.** Keep blades sharp and clean for best and safest performance. Follow instructions when lubricating and changing accessories.
- 16. Keep machine well guarded.** Make sure guards on machine are in place and are all working correctly.
- 17. Do not overreach.** Keep proper footing and balance at all times.
- 18. Secure workpiece.** Use clamps or a vice to hold the workpiece where practical. Keeping the workpiece secure will free up your hand to operate the machine and will protect hand from injury.
- 19. Check machine over before operating.** Check machine for damaged parts, loose bolts, Keys and wrenches left on machine and any other conditions that may effect the machines operation. Repair and replace damaged parts.
- 20. Use recommended accessories.** Refer to instruction manual or ask correct service officer when using accessories. The use of improper accessories may cause the risk of injury.
- 21. Do not force machinery.** Work at the speed and capacity at which the machine or accessory was designed.
- 22. Use correct lifting practice.** Always use the correct lifting methods when using machinery. Incorrect lifting methods can cause serious injury.
- 23. Lock mobile bases.** Make sure any mobile bases are locked before using machine.
- 24. Allergic reactions.** Certain metal shavings and cutting fluids may cause an allergic reaction in people and animals, especially when cutting as the fumes can be inhaled. Make sure you know what type of metal and cutting fluid you will be exposed to and how to avoid contamination.
- 25. Call for help.** If at any time you experience difficulties, stop the machine and call you nearest branch service department for help.



WARNING

Metal Lathe Safety Instructions

Machinery House
requires you to read this entire Manual before using this machine.

- 1. Maintenance.** Make sure the lathe is turned off and disconnect from the main power supply and make sure all moving parts have come to a complete stop before any inspection, adjustment or maintenance is carried out.
- 2. Lathe Condition.** Lathe must be maintained for a proper working condition. Never operate a lathe that has damaged or worn parts. Scheduled routine maintenance should be performed on a scheduled basis.
- 3. Leaving a Lathe Unattended.** Always shut the lathe off and make sure all moving parts have come to a complete stop before leaving the lathe. An unsupervised running lathe can cause serious injury.
- 4. Avoiding Entanglement.** Remove loose clothing, belts, or jewelry items. Tie up long hair and use the correct hair nets to avoid any entanglement with moving parts.
- 5. Chuck key safety.** Never let go of a chuck key while still in the chuck to prevent leaving the chuck key in the chuck. Chuck keys left in the chuck can cause serious injury.
- 6. Changing Chucks.** When changing large heavy chucks they become awkward to hold. Always get assistance when installing large chucks. Use a board or piece of plywood across the bedway when any install or removal of chucks to avoid any possible finger pinching between a loose chuck and edge of a bedway.
- 7. Tooling selection.** Always use the correct cutting tool for the job you are turning. Make sure it is sharp and held firmly in the tool post. Adjust the toolpost to provide proper support for the tool you will be using.
- 8. Mounting the workpiece.** Make sure the workpiece is properly mounted and secure before turning on the lathe. A loose workpiece can be thrown across the room and cause serious injury to you or a bystander.
- 9. Workpiece clearance.** Rotate the workpiece by hand to check for clearance with the tool post, compound slide and carriage before turning the lathe on.
- 10. Changing speeds and Reversing.** Turn the lathe off and make sure the lathe has come to a complete stop before changing speeds or reversing the spindle. Do not slow or stop the lathe chuck by using your hand.
- 11. Speed selection.** Select the appropriate speed for the type of work, material, and tool bit. Allow the lathe to reach full speed before beginning a cut.
- 12. Clearing chips.** Always use a brush to clear chips. Never clear chips when the lathe is running.
- 13. Power outage.** In the event of a power failure during use of the lathe, turn off all switches to avoid possible sudden start up once power is restored.
- 14. Clean work area.** Keep the area around the lathe clean from oil, tools and chips.
- 15. Call for help.** If at any time you experience difficulties, stop the machine and call your nearest branch service department for help.

PLANT SAFETY PROGRAM

NEW MACHINERY HAZARD IDENTIFICATION, ASSESSMENT & CONTROL

Metal Lathe

Developed in Co-operation Between A.W.I.S.A and Australia Chamber of Manufactures
This program is based upon the Australian Worksafe Standard for Plant(NOHSC:1010-1994)

Item No.	Hazard Identification	Hazard Assessment	Risk Control Strategies <small>(Recommended for Purchase / Buyer / User)</small>
A	ENTANGLEMENT	HIGH	Eliminate, avoid loose clothing / Long hair etc.
C	CUTTING, STABBING, PUNCTURING	MEDIUM	Isolate power to machine prior to any checks or maintenance. Do not open or clean inside until the machine has completely stopped.
D	SHEARING	MEDIUM	Make sure all guards are secured shut when machine is on. Isolate power to machine prior to any checks or maintenance.
F	STRIKING	MEDIUM	Ensure workpiece is secured in chuck and tooling is locked tight in toolpost. Always wear safety glasses. Do not leave chuck key in chuck. Remove all loose objects around moving parts.
H	ELECTRICAL	MEDIUM	All electrical enclosures should only be opened with a tool that is not to be kept with the machine.
N	HIGH - TEMPERATURE	LOW	Machine should be installed & checked by a Licensed Electrician.
O	OTHER HAZARDS, NOISE.	LOW	Wear appropriate protective clothing to prevent hot swarf. Wear hearing protection as required.
Plant Safety Program to be read in conjunction with manufactures instructions			





www.machineryhouse.com.au



www.machineryhouse.co.nz

Authorised and signed by:
Safety officer:

Manager:

.....

.....

Revised Date: Aug-08